ELVO

SOLDERING STATIONS

INSTRUCTION MANUAL
ELVO.010.5001.E

E911D



E911A



E912A

Dear customer

We thank you for selecting one of our ELVO **clean-o-point®** soldering stations, the new standard in soldering technology. The soldering stations answer the need for increased quality control in the soldering process. With the hundred thousands of **clean-o-point®** tip cleaners sold in the past number of years all over the world, satisfied customers urged us to integrate this extraordinary tip cleaning system into these new stations.

Please read the operating instructions carefully to maximize the advantages of using your new soldering station.

Responsibility for shipment

The moment the equipment is shipped from our plant, the buyer assumes all risks regarding it, in particular but not limited to the risk for damage, loss, theft or confiscation. We are liable only for damages which can undeniably be traced to gross negligence of our personnel.

Inspection of goods upon arrival

Remove packing material carefully and keep it for possible storing or return of the unit.

After unpacking, check the equipment for possible damage due to transportation. Should this be the case, inform immediately both the forwarder and the carrier. The buyer must examine the equipment within a reasonable period of time and notify us immediately **in writing** of any defects. Failing such notification the equipment is deemed to be accepted.

Warranty

The equipment has been carefully tested both mechanically and electrically prior to shipment. It has also been verified, as far as possible, that the equipment is in good working order. For a period of 12 months (6 months if the equipment operates day and night, even if only occasionally), beginning on the day the equipment is ready to be shipped at our plant (in cases where we undertake assembly and/or initial operation, from the day of initial operation), we guarantee good working of the equipment delivered and we promise to repair or replace at will, as quickly and reasonably as possible, any parts which are proven to be faulty in design, material or workmanship. If, during operation and within the period of warranty, any discrepancy appears between the equipment contracted for and the one actually supplied by us, we shall bear the costs incurred in repairing or replacing the faulty parts at our plant. We shall supply and ship at our expense "FOB factory" the replacement material necessary for carrying out the repairs under this warranty on the site. We shall pay the salary and wages of our employees, but the buyer shall pay for the travelling time, as well as their transportation and out of pocket expenses.

Our liability is limited to direct damages.

Our warranty shall not cover replacements or repairs which are due to normal wear and tear, faulty or negligent maintenance, disregard of operating instructions in this manual, overloading, use of unsuitable materials, faulty construction of buildings, incorrect assembly work, faulty electrical connections, acts of God, and any other cause beyond our control.

Our "General Terms and Conditions of Sale", of which the above text is an excerpt, are binding for all warranty cases.

This document, its contents, and the technology described are strictly confidential. It is provided for assistance to ELVO customers only. It may not be copied, reproduced or passed on to third parties without express, written permission from ELVO ELECTRONICS.

- Open this flap first !

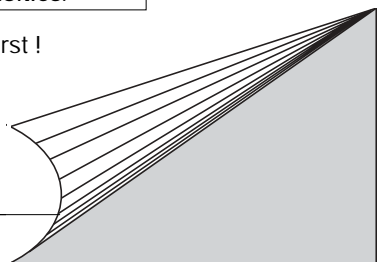

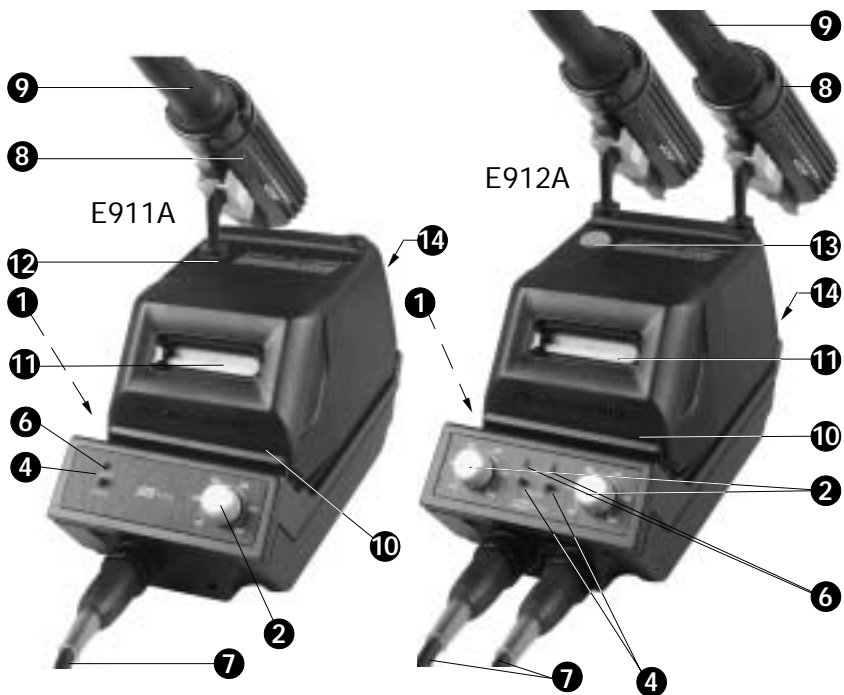
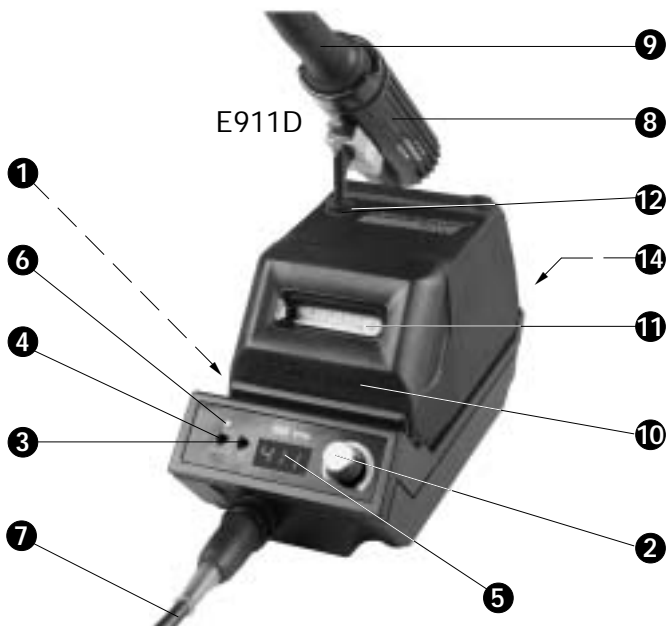







Legend

- ❶ Main switch
- ❷ Potentiometer for electronic temperature adjustment
- ❸ "SET" tumbler switch
- ❹ "Heater/Stand-by" tumbler switch
- ❺ Digital read-out (with E911D only)
- ❻ "Heater" LED heating control lamp
- ❼ Temperature resistant silicon-cable
- ❽ Iron holder
- ❾ Soldering iron with high-efficiency ceramics heating element and removable soldering tips (for tip selector chart see chapter 6.1)
- ❿ ***clean-o-point®***
Automatic patented soldering tips cleaning system.
The motorized moist sponge rollers are self-cleaning.
- ⓫ Round motorized sponge rollers
- ⓬ **Stop/Go switch**
Automatic for E911D and E911A
The self-cleaning motorized round sponges are only beginning to work when soldering iron is taken out of holder.
- ⓭ **Standard switch**
Manual for E912A
- ⓮ Connector socket (24 V) for mains supply unit

CONTENTS

1	PRODUCT DESCRIPTION	7
1.1	PRODUCT FEATURES	7
1.2	TECHNICAL DATA TYPE E911D / E911A / E912A	8
1.3	DIMENSIONED DRAWING	8
2	SAFETY CAUTIONS	9
2.1	SAFETY INFORMATION 	9
2.2	SAFETY CAUTIONS 	9
2.3	OPERATING PRECAUTIONS 	9
2.4	MECHANICAL PRECAUTIONS 	10
2.5	ELECTRICAL PRECAUTIONS 	10
2.6	MAINS PROTECTION 	10
2.7	THE ESD WORKING PLACE	10
2.7.1	ESD - Working place overview	11
3	INITIAL OPERATION	12
3.1	GENERAL FEATURES	12
3.1.1	Feature Description	12
3.2	COMPONENTS ASSEMBLY	12
3.3	TEMPERATURE RANGE	13
3.3.1	Temperature Stability	13
3.3.2	Working Temperature	13
3.4	OPERATING INSTRUCTIONS	14
3.4.1	<i>clean-o-point</i> [®] - How it works	15

4	MAINTENANCE	16
	4.1 GENERAL CLEANING	16
	4.2 CARE OF TIPS	16
	4.3 TIP REPLACEMENT AND DRESSING	17
	4.3.1 Commissioning of New Tips	17
	4.4 CLEAN-O-POINT® MAINTENANCE	18
5	SERVICING	19
	5.1 RETURN FOR REPAIRS	19
	5.2 CONDITIONS APPLYING TO SPARE PARTS	19
	5.3 SPARE PARTS LIST	20
6	ACCESSORIES	21
	6.1 SOLDERING TIPS	21
	6.2 SPARE SPONGES	21
7	DIAGRAMS	22
	7.1 BLOCK DIAGRAM E911D	22
	7.2 BLOCK DIAGRAM E911A	23
	7.3 BLOCK DIAGRAM E912A	24
8	ADDRESSES	25
	8.1 THE ELVO SALES-AND SERVICE SUPPORT	25
9	RECYCLING	28
	9.1 GENERAL RECYCLING	28
10	INDEX	29

ELVO Electronics Temperature Controlled Soldering Stations Type E911D / E911A / E912A with integrated Automatic Soldering Tip Cleaning are the new high performance standard for soldering equipment.

- Soldering of electronic components with electric or thermic sensitiveness like C-MOS-circuits, FET-transistors, LCD-read-outs
- Soldering with high requirements to the soldering connection, Military, Aviation and Space research
- Soldering with special solder (high and low melting) and connection within exact tolerances

1.1 PRODUCT FEATURES

- **clean-o-point®**, automatic soldering tip cleaner
- Accurate, stable temperature setting and control
- Variable temperature control
from 140-450° C (280-850° F) for digital version
from 150-400° C (300-840° F) for analog version
- Rapid heat up and instant recovery
- Digital read-out models
- Zero-voltage thyristor power switching
- Ultra-low tip leakage
- Comply with DOD and ML Specs

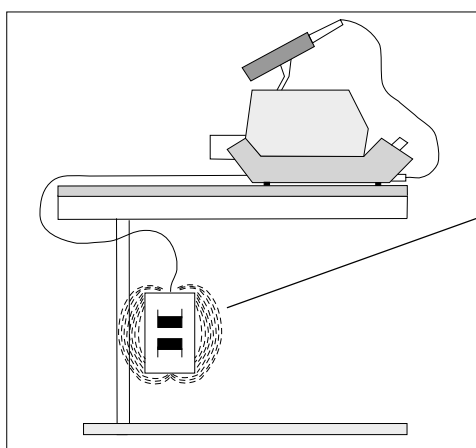

Mains supply unit:
Suspend outside the working zone using the assembly kit provided for this way you can avoid most efficiently any electromagnetic radiation.

1.2 TECHNICAL DATA TYPE E911D / E911A / E912A

Power supply	115 or 230 V~, 50/60 Hz
Heater voltage	24 V
Power of iron (wattage)	55 W
Temperature range	140-450° C (280-850° F) digital 150-400° C (300-840° F) analog
Tip leakage	< 2 mV
Standard Tip	Type ET 4520 S 2.0
Dimensions	See dimensioned drawing (below)
Weight	Mains supply unit: 1.4 kg (3.09 lbs) Soldering station: 1.1 kg (2.43 lbs)

1.3 DIMENSIONED DRAWING





2.1 SAFETY INFORMATION



Before installing and commissioning the soldering station, please study this instruction manual carefully. The enclosed measures and recommendations have to be followed.



Do never touch the soldering tip when the appliance is switched on (danger of burning)



When the the soldering station is open, it should always be handled when not under power (mains connection plugged off) and by authorized service personnel only

2.2 SAFETY CAUTIONS

Heeding the recommendations within the present manual will allow this apparatus to perform its highest capacity with maximum security.



2.3 OPERATING PRECAUTIONS

Following the instructions will enable high performance of the operations and ensure many long years of use. Adhere to following suggestions :



- **Handling the AC and other cables**

When connecting and disconnecting the cables, take hold of the plug section and not the cord. Pulling the cord may caused damage to the cable and create hazards.



- **Preventing electric shocks and fire hazards**

If the cable is broken or damaged, or if the wires are exposed, have it replaced !



- **The buyer has to install this appliance in such a way, that the security of the operator is guaranteed. Special care has to be taken with features, which are not mounted in a rack or similar.**

2.4 MECHANICAL PRECAUTIONS

Avoid subjective procession !



To guarantee a long standing stability in accordance to international rules, referring to security and reliability, all spare parts listed within this manual must be replaced with original items only.

In case of a component failure, only the assembly of an original, recognized component, will further the longevity.

2.5 ELECTRICAL PRECAUTIONS

AN ELECTRICAL SHOCK CAN BE FATAL !



It is at the own risk of the operator of an opened appliance, to understand the resulting danger of the above and to take the corresponding measures to protect third parties. Memorize the dangerous areas, which are exactly described in this manual. You should never touch simultaneously circuits and earth connections, during the installation or when servicing.

2.6 MAINS PROTECTION

ELVO soldering stations comply with the requirements of DOD-STD-2001-1, MIL-S-45743E, WS6536E and more. Electronic zero-voltage thyristor switching protects voltage and current-sensitive units and components against transient voltage spikes (computer, C-MOS components). Soldering tip is grounded to ensure a voltage leakage of less than 2 millivolt.





2.7 THE ESD WORKING PLACE

The ELVO technology includes a series of precautions for unproblematic soldering of MOS-electronic elements.

For working on high integrated MOS-elements with very fine structures like VLSI we recommend to build up a working place as mentioned below.



 Please do not use the SL as service ground because it may be connected with the neutral conductor and consequently may not be free from disturbing voltages (e. g. unsymmetrical three phase mains).

 Please note that a short in a defective instrument can induce a high pulse with voltage peaks of more than 100 V.

2.7.1 ESD - Working place overview

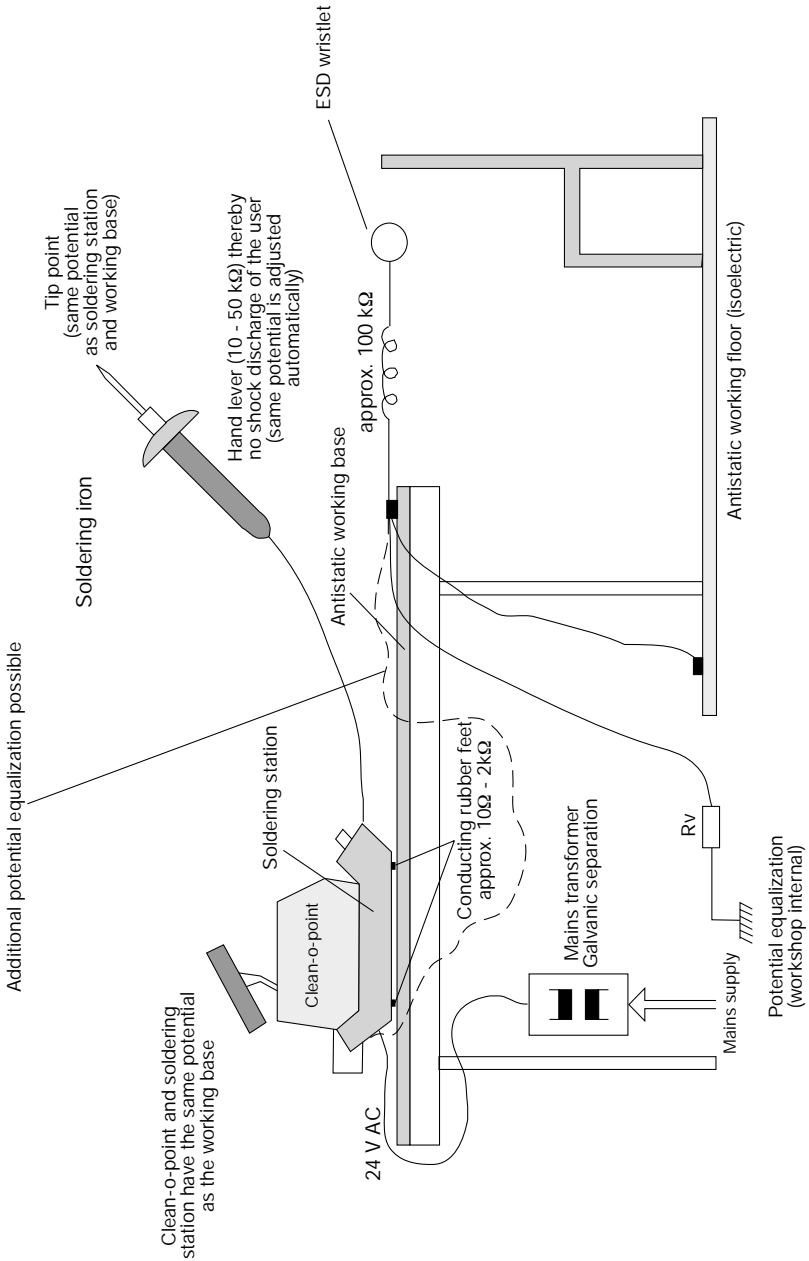

3.1 GENERAL FEATURES

- Soldering stations E911D / E911A / E912A
- **clean-o-point®**
- Soldering iron 55 Watt
- Iron holder
- Transformer
- Suspension device with hock screw
- Bag with spare sponges
- Copper cleaning brush
- Instruction manual

3.1.1 Feature Description

- Socket for potential equalization is installed on the rear side (to avoid leakage of static charges)
- The soldering station is isolated from AC line by a transformer and only 24 V AC isolated voltage is used to drive the heating element
- All housing parts are molded of high impact and high heat resistant polycarbonate.
- The soldering iron is connected to the soldering station using a temperature resistant and antistatic silicone rubber sheathed cable with a five pin heavy duty plug with locking ring

3.2 COMPONENTS ASSEMBLY

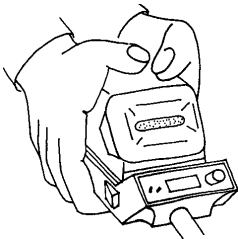

Assembly:

Press the station and the **clean-o-point®** firmly together with both hands.

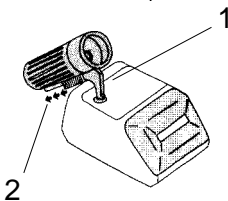

Iron holder:

Insert until it snaps in (1).

With the models E911A and E911D, the Stop + Go switch can be blocked (if desired) by pushing the corresponding slide lever backwards (2).



Transformer with suspension device

3.3 TEMPERATURE RANGE

ELVO soldering station delivers the full operating range of 140-450° C (280-850° F) in the digital version and 150-400° C (300-840° F) in the analog version without changing tip or heating element. The ceramics heating element ensures the accurate temperature close to the surface of the tip. This results in rapid heat up time of about 45 seconds and instant recovery.

3.3.1 Temperature Stability

Tip idling temperature stability is smaller than $\pm 3^{\circ}\text{C}$ ($\pm 10^{\circ}\text{F}$), corresponding to MIL requirements. This is accomplished by embedding the thermocouple sensing unit in the bevel of the heating element barrel. The measuring point is nearest to the soldering tip. Only this method allows the closest possible monitoring of the temperature.

3.3.2 Working Temperature

A too low temperature will slow the solder flow; a high temperature will burn the flux in the solder, which in turn will emit a heavy white smoke in a dry joint, or damage the PCB. When the tip working temperature is set within the correct parameters suited to the particular solder being used a good joint is assured. The most common solder alloys used in the electronic industry is 60% tin, 40% lead (60/40). The tip working temperature of the solder is detailed below and can vary from manufacturer to manufacturer:

Melting point:	188° C (370° F)
Normal operation:	270-320° C (518-608° F)
Production line operation:	320-380° C (608-716° F)



The temperature above 380° C (716° F) should not be used for normal soldering functions but can be used for short periods of time when excessive heat is required.

Consider the recommendations of the manufacturers of the different components !



3.4 OPERATING INSTRUCTIONS

	E911D	E911A / E912A
1.	Connect unit to mains. Switch unit on. Green "Heater" light will turn on.	Connect unit to mains. Switch unit on. Green "Heater" light will turn on.
2.	The temperature will be read on digital LED display.	-
3.	Set nominal temperature by holding "SET" switch 3	-
4.	Rotate temperature control knob until digital display reads desired temperature (resolution $\pm 1^\circ$)	Rotate temperature control knob to the desired temperature
5.	Release "SET" switch. Tip temperature is now rising and being displayed.	-
6.	During any work breaks, move the switch on the left to "Standby". When starting work again, move it back to "Heater" so that the temperature last used will be reset automatically.	During any work breaks, move the switch on the left to "Standby". When starting work again, move it back to "Heater" so that the temperature last used will be reset automatically.

3.4.1 *clean-o-point*[®] - How it works

The *clean-o-point*[®] cleans tips with a remarkable self-cleaning motorized wiping system that keeps tips clean, prolongs tip life, removes and collects excess solder. Fast 1 second cleaning with damp sponges means no temperature loss at the tip, no cold solder points to destroy PC boards.

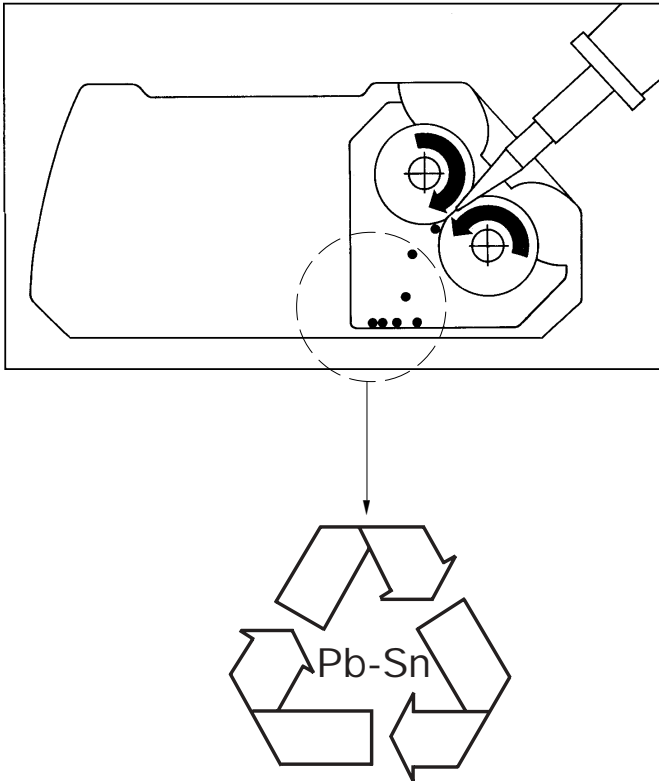

see also chapter 4.4 - *clean-o-point*[®] maintenance



4.1 GENERAL CLEANING

The outer case of iron or station may be cleaned with a damp cloth using little amounts of liquid detergents.



Never submerge the unit in liquid or allow any to enter the case of the station.



**Never use any solvent to clean the case.
(Decomposition of the writing and / or deformation on the housing)**



4.2 CARE OF TIPS

The tips supplied are iron plated copper and if used properly will give a long life.

1. Always keep tips tinned before switching off or storing for a long period of time; Wipe tip using clean-o-point.

Caution with long hair!



2. **Don't keep iron set at high temperature for long periods as this will break down the surface of the tip.**



3. Never clean tips with abrasive materials or files.
4. If any oxide film is formed, this can be cleaned with the cleaning brush, isopropyl alcohol or equivalent, and then immediately reheat and retain the tip to prevent oxidation of wettable surface.
5. Remove the tip and clean every twenty-four hours or at least once a week. Remove any loose build up in the barrel.
6. **Do not use fluxes containing chloride or acid.
Use only rosin or activated resin fluxes.**
7. Do not use any compound or antiseize materials on the wettable surface.



4.3 TIP REPLACEMENT AND DRESSING

Tip can be replaced simply by unscrewing the knurled nut barrel assembly. The station must be switched off and allowed to cool during this operation, **as damage may result if the system is left on without the tip inserted**. After removing tip, blow out any oxide dust that may have formed in the tip retaining area of the barrel. Be careful to avoid getting dust in your eyes. Replace the tip and screw back the retaining knurled nut barrel assembly using only firm hand pressure to tighten. Pliers should only be used to tighten the nut to avoid burning your fingers.



Wear protection spectacles!



Care should be taken not to overtighten as this would damage the heating element.



4.3.1 Commissioning of New Tips



The following procedures should be followed when a new tip has been installed at any time. It will give the tip much longer life.

1. Set temperature to the minimum, then switch power to "ON".
2. After approx. 1 minute set temperature to 200° C (392° F). (Beginning of scale)
3. Tinn the surface with resin core solder containing colophonium after having reached 200° C (392° F).
4. Set to desired temperature and let it heat for approx. 5 minutes.
5. Ready for use after reaching the present desired temperature.



**Important: Remove tip and clean daily if a new tip is installed and removed any loose build up in the barrel !
(For Tip Selector Charts, see chapter 6 !)**



4.4 *clean-o-point*[®] MAINTENANCE

1. Before using for the first time, wash sponges carefully under running water.
2. Rinse sponges under running water once only before beginning the shift, and wring well. If the soldering tips are very fine, wring more thoroughly. The sponges retain uniform humidity for about 8 hours.
3. Do not wet the sponges by pouring water over them in the unit. Overly wet sponges will cause excessive cooling of soldering tips.
4. Replace sponges when incrustated with rosin (after about 1 month of all-day shifts).

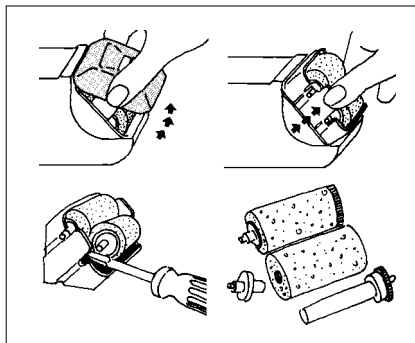

Sponges are much cheaper than soldering tips !



5. Empty solder container before starting each 8-hour shift. Wash and wring sponge rollers well.



Collect solder for recycling !

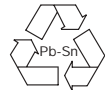

6. To clean the soldering tip, insert it with a steady movement between the wet rotating sponge rollers. Cleaning takes less than 1 second !
7. Soldering tips cleaned with *clean-o-point*[®] have a service life up to 10 times longer than tips cleaned with common flat sponges.

5.1 RETURN FOR REPAIRS

Should it prove necessary in the future to send the equipment back for repair, please proceed as follows :

- enclose an exact description of the failure, including the operational mode in which the failure or breakdown first occurred
- indicate clearly the person that should be contacted in your company and indicate the telephone and fax number
- for transportation, please use the original packing material (as far it is still available). Should this no longer be available, please make sure that the package protects the equipment adequately.
- assuming it is necessary and possible, send the entire equipment back (soldering station and mains supply unit, accessories etc.)

You can of course contact our service or sales departments by telephone, telex or telefax. Our customer service will gladly assist you. Addresses are listed in chapter 8



In order to assure best performance in function of your ELVO soldering station, please consider following points. In case of a function failure, please contact your next ELVO specialist.



5.2 CONDITIONS APPLYING TO SPARE PARTS

Only use original spare parts. Chapter 5.1 contains a list of standard spare parts.

To use products from another source could harm

- safety,
- reliability and
- performance.

5.3 SPARE PARTS LIST

Sender (Company name):

.....

Send, ATTENTION to:

.....

ORDER FORM

Unit serial number:





(on the technical label)

For a quick response to your spare parts requirement kindly use the list below. Just fill in the quantity of each part you require and send it to us - Thank you. You will find the addresses at the end of this manual.



Part no.	Pos.	Description	Qty	Order-qty
ET4500	9	Soldering iron 55 W	1	
ET4550		Heating element	1	
ET4520		Soldering tips Type S, B, C	1	
ET4521		Soldering tips Type SL, SS, CA	1	
ET4522		Soldering tips SMD Type SM8 SM14	1	
		Type SM16 SM23	1	
		Type SM0805 SM1206	1	
		Type SM5588	1	
ET4523		SMD-Adapter	1	
ET4524		Cleaning brush, Copper	1	
ET3008		Spare sponges, (bag of 8 pieces)	1	
ET3010		Front cover, black	1	
ET3011		Tinbox, axe standards included	1	
ET3012	8	Iron holder assembly	1	
ET3015		Axe standards to tinbox ET3011	1	
ET3016		Box ESD, black	1	
ET3017		Box, green	1	
ET3019		Holder	1	
ET3020		Rocker switch	1	
ET3021		Complete switch to "Stop & Go"	1	
TR4200		Supply unit to E911D/A 230 VAC / 50 VA	1	
TR4220		Supply unit to E912A 230 VAC / 100 VA	1	
TR4111		Supply unit to E911D/A 115 VAC / 50 VA	1	
TR4121		Supply unit to E912 A 115 VAC / 100 VA	1	

6.1 TIPS

 <p>Length = 46 mm (1.81")</p>	<p>Screw Driver Shape</p> <table border="1"> <thead> <tr> <th>Order number</th> <th>Dim.</th> </tr> </thead> <tbody> <tr> <td>4520 S 1.0</td> <td>≥ 1/32"</td> </tr> <tr> <td>4520 S 1.5</td> <td>1/16"</td> </tr> <tr> <td>4520 S 2.0</td> <td>5/64"</td> </tr> <tr> <td>4520 S 2.5</td> <td>3/32"</td> </tr> <tr> <td>4520 S 3.0</td> <td>1/8"</td> </tr> <tr> <td>4520 S 3.6</td> <td>≤ 5/32"</td> </tr> <tr> <td>4520 S 4.8</td> <td>3/16"</td> </tr> </tbody> </table>	Order number	Dim.	4520 S 1.0	≥ 1/32"	4520 S 1.5	1/16"	4520 S 2.0	5/64"	4520 S 2.5	3/32"	4520 S 3.0	1/8"	4520 S 3.6	≤ 5/32"	4520 S 4.8	3/16"
Order number	Dim.																
4520 S 1.0	≥ 1/32"																
4520 S 1.5	1/16"																
4520 S 2.0	5/64"																
4520 S 2.5	3/32"																
4520 S 3.0	1/8"																
4520 S 3.6	≤ 5/32"																
4520 S 4.8	3/16"																
 <p>Length = 46 mm (1.81")</p>	<p>Conical Shape</p> <table border="1"> <thead> <tr> <th>Order number</th> <th>Dim.</th> </tr> </thead> <tbody> <tr> <td>4520 C 0.3</td> <td>1/64"</td> </tr> <tr> <td>4520 C 0.6</td> <td>.025"</td> </tr> <tr> <td>4520 C 0.8</td> <td>1/32"</td> </tr> </tbody> </table>	Order number	Dim.	4520 C 0.3	1/64"	4520 C 0.6	.025"	4520 C 0.8	1/32"								
Order number	Dim.																
4520 C 0.3	1/64"																
4520 C 0.6	.025"																
4520 C 0.8	1/32"																
 <p>Length = 46 mm (1.81")</p>	<p>Pointed Shape</p> <table border="1"> <thead> <tr> <th>Order number</th> <th>Dim.</th> </tr> </thead> <tbody> <tr> <td>4520 B 1.6</td> <td>1/16"</td> </tr> <tr> <td>4520 B 2.5</td> <td>3/32"</td> </tr> <tr> <td>4520 B 3.0</td> <td>1/8"</td> </tr> <tr> <td>4520 B 4.8</td> <td>3/16"</td> </tr> </tbody> </table>	Order number	Dim.	4520 B 1.6	1/16"	4520 B 2.5	3/32"	4520 B 3.0	1/8"	4520 B 4.8	3/16"						
Order number	Dim.																
4520 B 1.6	1/16"																
4520 B 2.5	3/32"																
4520 B 3.0	1/8"																
4520 B 4.8	3/16"																
 <p>Length = 52 mm (2.05")</p>	<p>Screw Driver Shape</p> <table border="1"> <thead> <tr> <th>Order number</th> <th>Dim.</th> </tr> </thead> <tbody> <tr> <td>4521 SL 1.2</td> <td>1/32"</td> </tr> <tr> <td>4521 SL 1.6</td> <td>1/16"</td> </tr> <tr> <td>4521 SL 2.0</td> <td>5/64"</td> </tr> <tr> <td>4521 SL 3.2</td> <td>1/8"</td> </tr> </tbody> </table>	Order number	Dim.	4521 SL 1.2	1/32"	4521 SL 1.6	1/16"	4521 SL 2.0	5/64"	4521 SL 3.2	1/8"						
Order number	Dim.																
4521 SL 1.2	1/32"																
4521 SL 1.6	1/16"																
4521 SL 2.0	5/64"																
4521 SL 3.2	1/8"																
 <p>Length = 52 mm (2.05")</p>	<p>Conical cranked</p> <table border="1"> <thead> <tr> <th>Order number</th> <th>Dim.</th> </tr> </thead> <tbody> <tr> <td>4521 CA 0.8</td> <td>1/32"</td> </tr> </tbody> </table>	Order number	Dim.	4521 CA 0.8	1/32"												
Order number	Dim.																
4521 CA 0.8	1/32"																



For SMT tips, ask for additional information

6.2 SPARE SPONGES

	<p>Spare sponges</p> <p>8 pieces</p> <p>Order number F3008</p>
---	--

7.1 BLOCK DIAGRAM E911D

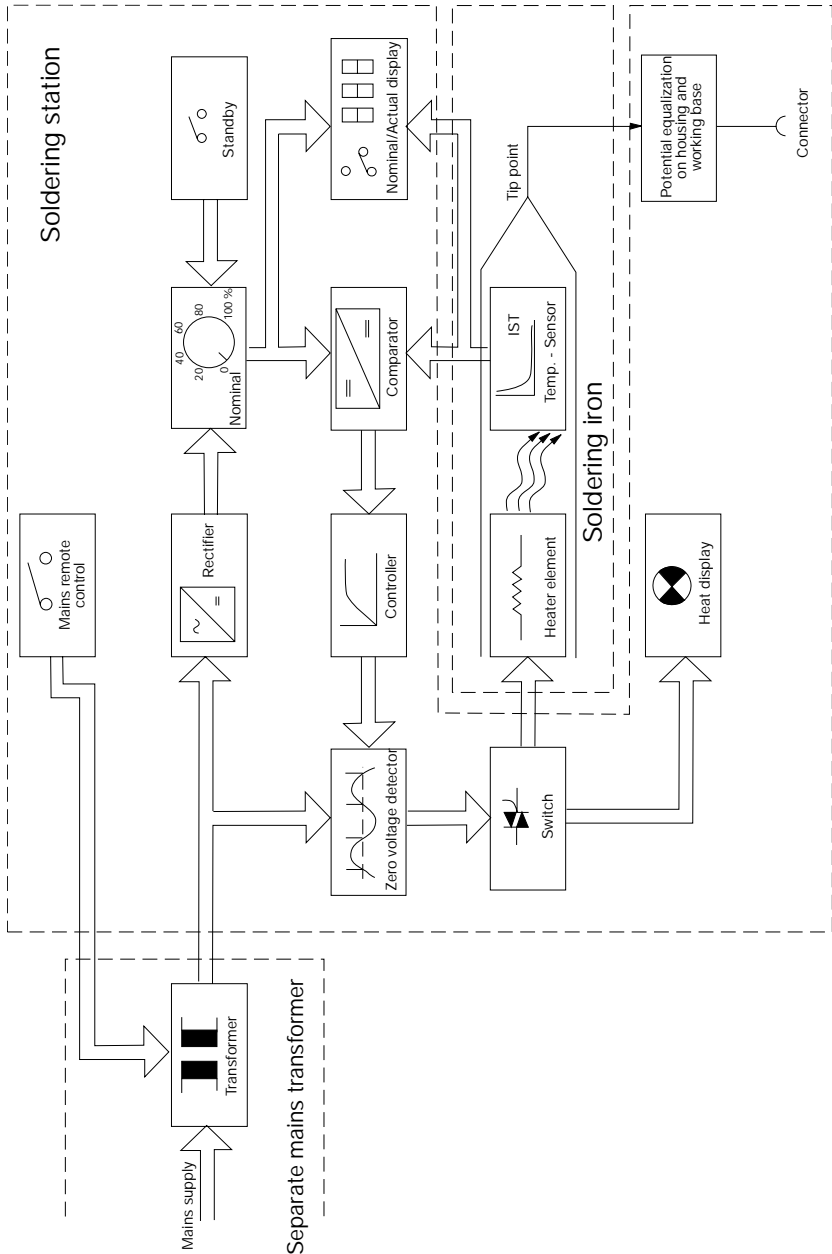

7.2 BLOCK DIAGRAM E911A

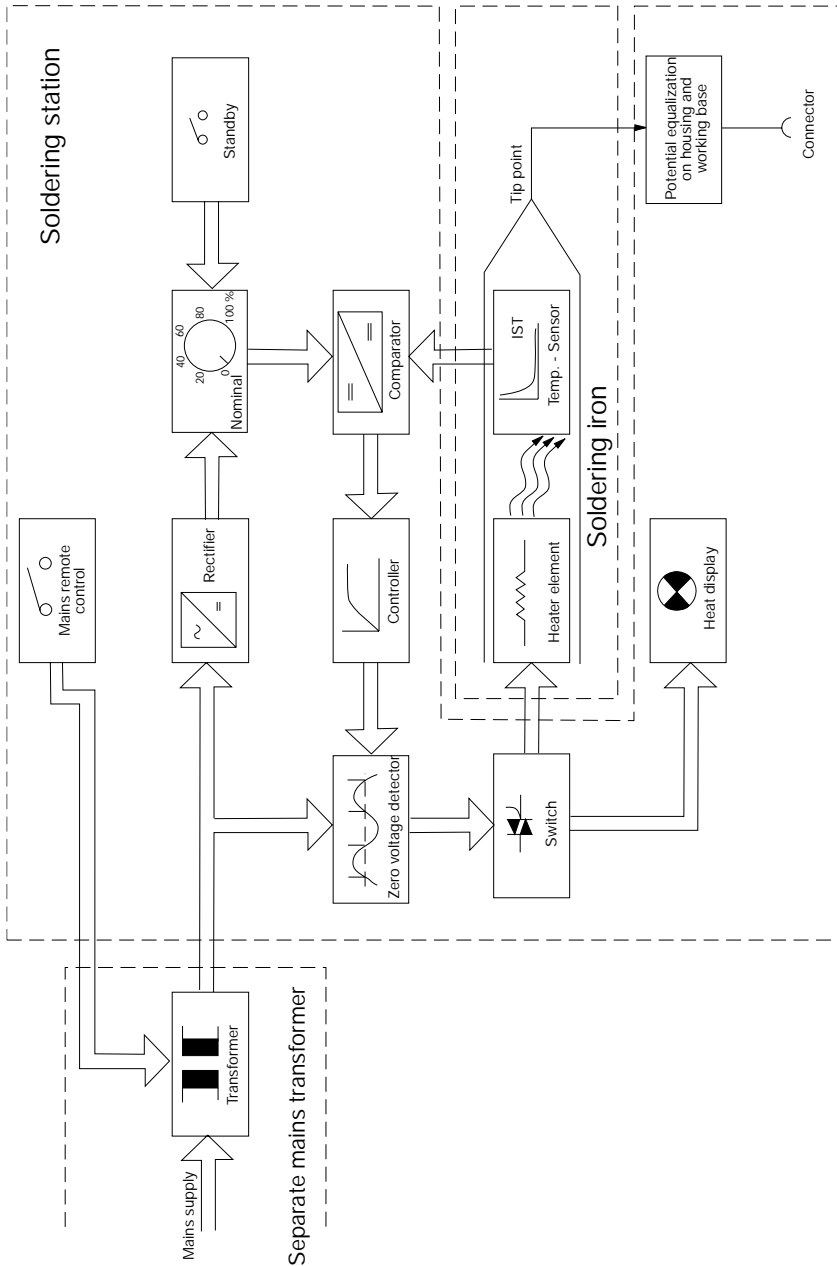

7.3 BLOCK DIAGRAM E912A

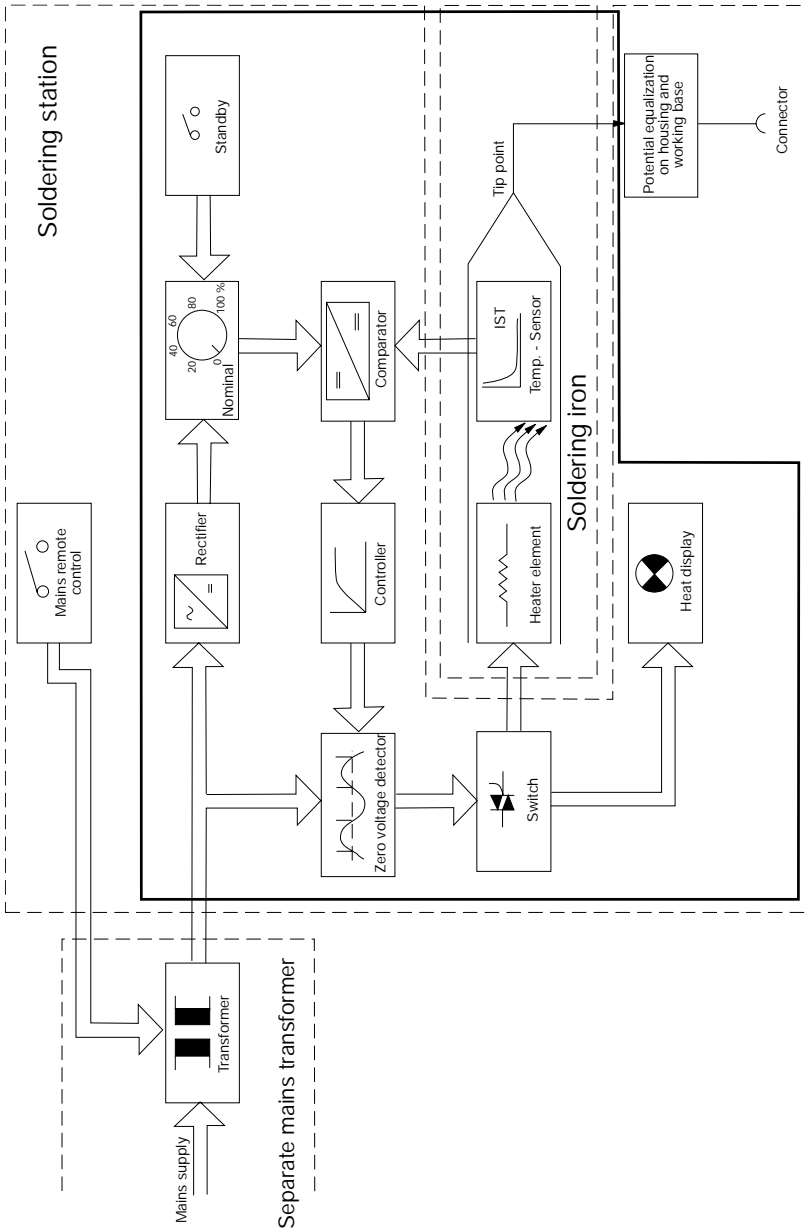

This part is installed twice in Type 912A

8.1 THE ELVO SALES- AND SERVICE SUPPORT

Switzerland ELVO Electronics AG

(H.Q.) Hauptstrasse 93
 CH-2552 Orpund
 Schweiz
 Tel ++ 41 / (0)32 / 356 04 31
 Fax ++ 41 / (0)32 / 356 04 32
 info@elvo.ch
 www.elvo.ch

Brütsch/Ruegger AG

Postfach
 CH-8010 Zürich
 Tel ++41 / (0)44 / 736 63 63
 Fax ++41 / (0)44 / 736 63 60

EGLI, FISCHER & CO. AG

Gotthardstrasse 6
 CH-8022 Zürich
 Tel ++41 / (0)44 / 209 81 11
 Fax ++41 / (0)44 / 201 22 75

Ernst Hess AG / SES-Sterling

Metzerlenstrasse 38
 CH-4115 Mariastein
 Tel ++41 / (0)61 / 731 34 16
 Fax ++41 / (0)61 / 731 34 89

NEUTEC

Mettlenbachstrasse 29
 CH-8617 Mönchaltorf
 Tel ++41 / (0)44 / 948 17 11
 Fax ++41 / (0)44 / 948 17 37

Simpex Electronic AG

Binzackerstrasse 33
 CH-8622 Wetzikon
 Tel ++41 / (0)44 / 931 10 10
 Fax ++41 / (0)44 / 931 10 11

SIBALCO

W. Siegrist & Co. AG
 Birmanngasse 8
 CH-4009 Basel
 Tel ++41 / (0)61 / 264 10 10
 Fax ++41 / (0)61 / 264 10 15

Austria JI+C WarenvertriebsgesmbH

Theresianumgasse 13
 A-1040 Wien
 Tel ++43 / 1 812 27 39
 Fax ++43 / 1 812 10 81

FAIR-TRADE

Mittelstrasse 63
 A-2203 Manhartsbrunn
 Tel ++43 / 224 583 9900
 Fax ++43 / 224 583 9903

Belgium Arcoss BVBA

Bremheidelaan 8
 B-2300 Tunrhout
 Tel ++32 / 144 201 51
 Fax ++32 / 144 225 51

Czech. Republic ABE TEC s.r.o.

Prumyslova 387
 CZ-53003 Pardubice
 Tel ++ 420 / 466 670 192
 Fax ++ 420 / 466 655 127

Denmark Hin Hørsen A/S

Langmarksvej 29
 DK-8700 Horsen
 Tel ++ 45 / 7625 90 90
 Fax ++ 45 / 7625 90 91

France A. Jahnichen

38, Rue de Peupliers
 F-92008 Nanterre Cedex
 Tel ++33 / 1 47 86 84 40
 Fax ++33 / 1 47 86 16 01

Germany Technisches Büro KULLIK & Partner Vertriebs GmbH

Mettgenberg 3
 D-58540 Meinerzhagen
 Tel ++ 49 / 235 790 9510
 Fax ++ 49 / 235 790 9595

Hungary **Ferrumino**
Királi utca 9
HU-1042 Budapest
Tel ++36 1 379 0417
Fax ++36 1 379 0418

Nóniusz Kft.
Köbányai u. 47/b
HU-1101 Budapest
Tel ++36 1 350 4326
Fax ++36 1 350 6459

Italy **COFIL MACCHINE**
Via Privata Schiatti
I-20057 Vedano al Lambro / MI
Tel ++39/39 49 20 15
Fax ++39/39 49 15 79

Japan **CLAY & COMPANY LTD**
4-6-8 Kawara-Machi, Chuo-Ku
Osaka Kagaku Seni Kaikin 3a
J-Osaka City
Tel ++81/6 204 43 55
Fax ++81/6 204 43 62

Korea **SE HAN Electools Ltd.**
B-508-1, Bundang Techno Park
Yatap-dong 148, Bundang KU
Songnam. Kyonggi-DO
Korea 463-070
Tel ++82/2 277 48 72
Fax ++82/2 272 93 73

Malaysia **Broad-line Corp. SDN BHD**
25, Jalan Radin Anum 2
Seri Petaling
MY-57000 Kuala Lumpur
Tel ++65/3 9057 0091
Fax ++65/3 9059 3273

Netherlands **Unitek Eapro**
Schootensee Dreef 21
NL-5700 AD Helmond
Tel ++ 31/4925 42 225
Fax ++ 31/4925 36 222

Norway **KREPRO AS**
Bonsdalsvn. 32
Postboks 233
N-2070 Raholt
Tel ++ 47/639 953 320
Fax ++ 47/639 953 933

Philippines **MVENT**
Market Venture Philippines Inc.
523 Santissima Trinidad St.
San Antonio Valley 6
PH-1707 Paranoque City
Tel ++63/2 825 97 84
Fax ++63/2 825 43 44

Singapore **CHIP HUA EQUIPMENT
AND TOOLS PTE Ltd.**
701 Sims Drive
#02-04 LHK Building
SG-Singapore 337383
Tel ++65/6298 30 88
Fax ++65/6297 00 29

Slovakia **Mikrona Mkroelektronické
Prvky Systémy**
Ku Bratke 1
SK-93505 Levice
Tel ++421/366 310 430
Fax ++421/366 312 497

Slovenia **Atech Elektronika**
Bac pri Meteriji 30
SL-6242 Materija
Tel ++386/568 000 01
Fax ++386/568 742 441

**Spain
Portugal** **Bielec Electronics S.L.**
Carme Karr, 13
E-08034 Barcelona
Tel ++34/932 802 989
Fax ++34/932 804 113

Sweden**Cyncronica AB**

Tomtbergavägen 2
SE-14567 Norsborg

Tel ++46/853 194 300

Fax ++46/853 194 310

Filtronic AB

Box 2284
Hissgatan 2
SE-531 40 Lidköping

Tel ++46/510 208 10

Fax ++46/510 210 40

Taiwan**KINGYOUP ENTERPRISES CO.**

4F-16., No.16, Lane 609, Sec. 5
Chung Hsin Road
TW-Taipei County

Tel ++886/2 999 17 50

Fax ++886/2 999 17 47

UK**Link Hamson Ltd.**

5 The Gateway Centre
Coronation Road
Cressex Bus Park
GB-High Wycombe HP12 3SU

Tel ++ 44/1494 439 786

Fax ++ 44/1494 526 222

USA**ELVO Division of
Zumbach Electronics Corp.**

140 Kisco Avenue
Mount Kisco, NY 10549-1412
Phone ++1/914 241 7080
Fax ++1/914 241 7096
e-mail: sales@zumbach.com

9.1 GENERAL RECYCLING

All individual components of the unit described in this manual have to be treated according to the local regulations for recycling (batteries, metals etc.) or for safe disposal (printed circuit boards etc).

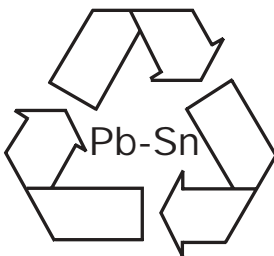

A

ACCESSORIES	21
ADDRESSES	20, 25

B

Block diagram	22, 23, 24
---------------	------------

C

Care of tips	16
Clean-o-point	2, 4, 7, 12, 15, 16, 18
Cleaning	2, 4, 7, 15, 16, 18, 19
Components Assembly	12

D

Dimensioned drawing	8
---------------------	---

E

ESD	10, 11, 12, 19
-----	----------------

F

Features	7, 9, 12
----------	----------

G

General Cleaning	16
------------------	----

M

Maintenance	2, 15, 16, 18
Mains protection	10
MOS	7, 10, 13

O

Operation	2, 12, 13,
-----------	------------

P

Product Features	7
------------------	---

R

Recycling	18, 28
-----------	--------

S

SAFETY CAUTIONS	9
SERVICING	19
Spare Parts	19, 21
Sponges	12, 18, 19, 21

T

Technical data	8
Temperature	4, 7, 8, 13, 14
Temperature range	8, 13
Temperature Stability	13
Tip Replacement	17
TIP SELECTOR CHART	17, 20

W

Working place overview	11
Working Temperature	13



Subject to change without notice.

Printed in Switzerland

ZUMBACH Electronic AG
P.O. Box
CH-2552 Orpund

December 2006

clean-o-point®

ELVO

Switzerland

ELVO ELECTRONICS AG

Hauptstrasse 93

CH-2552 Orpund

Tel: ++41/(0)32/356 04 31

Fax:++41/(0)32/356 04 32

I: www.elvo.ch

E: info@elvo.ch

The future belongs to quality and excellence
